

HELLER
Machines

HELLER
Machines

HELLER Machines. Made to work.
www.heller-machines.com

HELLER
Automotive

Inside Competence.
Our extensive know-how allows us to offer innovative and comprehensive production solutions for powertrain, drivetrain and chassis components. Highly productive. For minimal piece-part costs.

HELLER
Machines

Made to work.
Application know-how and technological competence to cater for all production requirements. With a new generation of machining centres offering a wide range of options in our proven quality.

HELLER
Services

Just closer to you.
Individual services and custom-made service packages ensure optimum productivity and highest availability of your machines. Anywhere in the world, on site and around the clock.

Some of the options shown are not included in the basic scope of supply. Design and scope of supply are subject to technical changes. © Gebr. Heller Maschinfabrik GmbH © conceived and written by: SK+P, München-Unterföhring, designed by: echolot, Stuttgart, September 2007.

HELLER Machining Centres

The new H 2000 / H 4000
For individualists



HELLER Machines:
you can only win 2

The H series:
reliable performance packages 4

The machine concept:
H 2000 / H 4000 6

Simply more HELLER:
extensions and options 10

SPEED PACK:
for high-speed cutting 12

POWER PACK:
for heavy cutting 14

Operation:
proven and perfected 16

Maintenance:
in a flash 17

Made to work. H 2000 / H 4000.

Horizontal machining centres with the productivity seal of approval

HELLER stands for high-end machining with maximum productivity. HELLER Machines benefit from the know-how and experience gained through many decades in the manufacture of machining centres. Let us show you how you can profit from our experience – you can only win!

When you're dealing with challenging manufacturing tasks, you want all the solutions from one source. HELLER Machines has the answer to your needs. Due to our comprehensive application know-how and high level of technological competence we can provide solutions for all requirements of modern production. A new generation of versatile machining centres with a wide range of options rounds off our product range with a clear focus on our customers' needs whilst always providing the typical extra quality from HELLER: a plus in productivity, security and flexibility.

HELLER Machines aims to build machines precisely tailored to your production needs. With this aim in mind we have now transformed and refined our business portfolio for you.

There's a lot we can do for you. Let's get started!

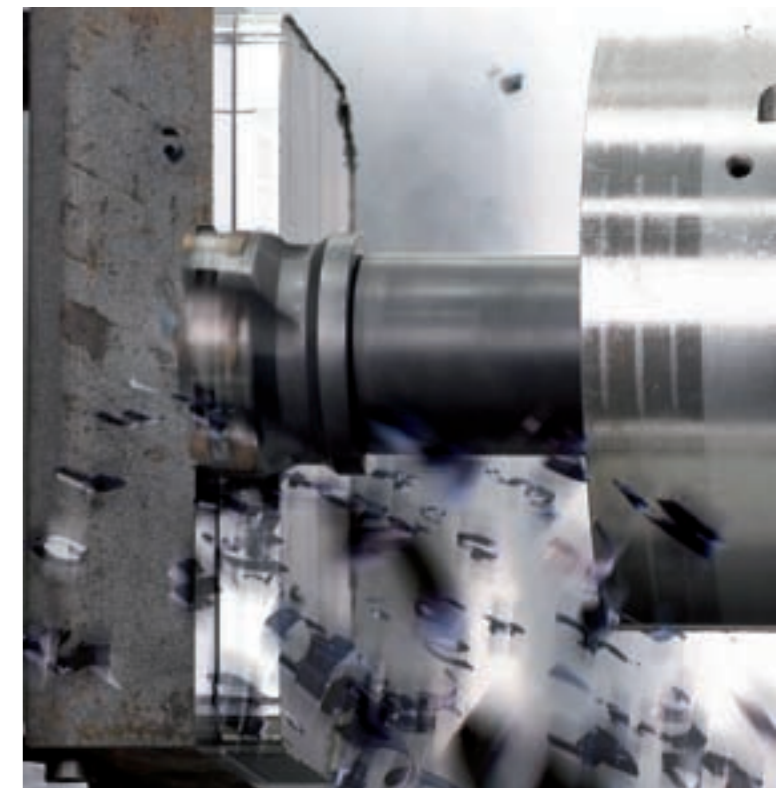

The H series: reliable performance packages



One for all

You need machining centres that can be fully customised to your requirements whilst offering an attractive price/performance ratio and the confidence that they will produce reliably even under extreme loads. Therefore our task was to develop a range of highly standardised but flexible machines with unbeatable load capacity.

Tailor-made off the peg

Due to the modularity of the variants and options available for the new H series, customers can configure their own "tailor-made off the peg" machining centre. Spindle, spindle taper, tool magazine, chip disposal can be selected according to individual requirements and machining strategy. With options proven in everyday production HELLER machining centres can be transformed into customised performance packages.

Realistic dynamic rates

All machines from the new H series have one thing in common: they offer unbeatable productivity. The machines have been adequately designed to provide minimal positioning times. Consequently the H series can do without extreme rapid traverse and acceleration rates, so that the machines are not unnecessarily subjected to extreme loads. This enhances the machine life and provides additional savings.

Robust processes

Gaining a few tenths of a second is not what makes the difference, what counts is that production runs smoothly. The new H series was designed for stable processes in day-to-day production: proven components, adequate speeds and a wide range of standard equipment that can be extended with numerous options. In brief: a robust machine that can be run at full load even to the limit, seven days a week in 3-shift operation.

Machining at its best

HELLER is synonymous with milling. For us that is a promise and commitment at the same time. Whether it's high-speed cutting, heavy cutting, dry or MQL machining: the machining centres from the H series are suitable for any machining strategy and provide high productivity throughout all disciplines.

Application experience you can feel

Reliability and ease of operation are important factors for availability. With the H series you can benefit from our application experience every day - whether it's the workpiece setting station, tool loading or programming. We have also completely revised the maintenance concept for the H series, a factor that has a crucial influence on the lifecycle costs of a machine.

HELLER's H series – a bit more of everything.

Machine concept H 2000 / H 4000

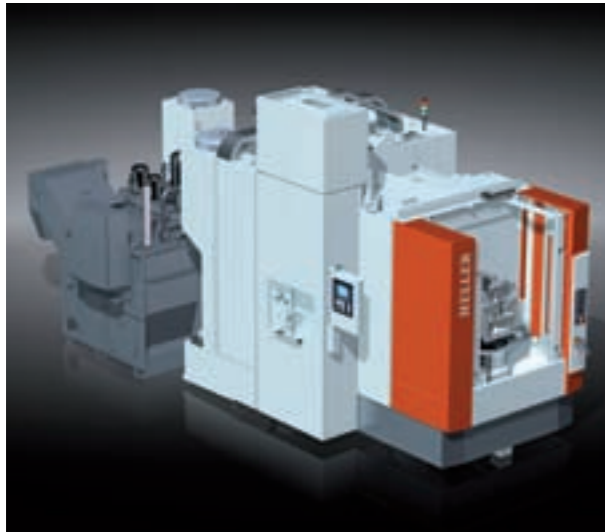

Sizes H 2000 / H 4000

- X = 630 mm / 800 mm
- Y = 630 mm / 800 mm
- Z = 630 mm / 800 mm

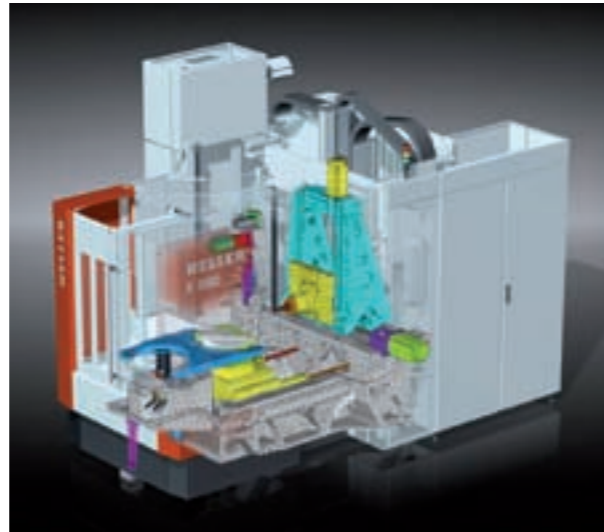

Machine bed and column

- Optimised with state-of-the-art simulation technology**
- Optimised topology of structural components resulting from many years of experience from in-house simulation
 - Inherently rigid machine bed
 - Cast components, e.g. column and rotary tables designed to provide rigidity

The benefits to you:

- Installation without anchoring ensures high flexibility for machine installation
- High cutting performance and precision for every machining strategy
- Cost-effective price

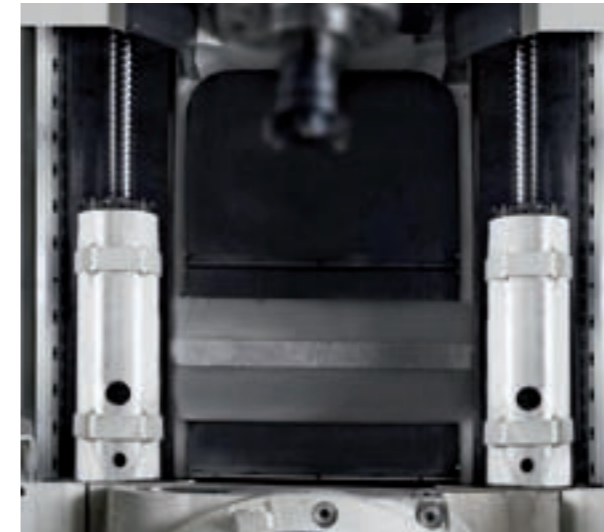

Drive technology

- Enhanced power and precision**
- Twin drive in the Z-axis for symmetric force application and free chip fall
 - Ball screw drives arranged in-between linear guideways
 - Reduced performance demands on the individual ball screw drives at ultra-short positioning times

The benefits to you:

- High precision thanks to twin drive in Z-axis
- Reduced table deformation and higher precision with drives arranged on the inside
- Minimal axes positioning times ensure high productivity
- Reduced wear for low operational cost



Spindle

- Highest precision made by HELLER**
- Proven zero-spindle system based on extensive HELLER know-how
 - Maintenance-friendly, modular spindle unit
 - In-house manufacturing competence ensures highest quality
 - High accuracy due to precision cooling
 - Spindle variants for eco, power, speed and high-speed cutting
 - Clear spindle nose allows extended reach into the workpiece
 - Innovative coolant purging for spindle and tool
 - SK 40, HSK 63, BT 40 spindle tapers

The benefits to you:

- Zero-spindle system ensures fast and cost-effective exchange of the spindle
- Stiff spindle nose for high process stability
- Dynamically stiff, short design of the spindle unit and water-cooled spindle neck provide high precision
- Reduced coolant dispersion provides cleaner machine and tools

Machine concept H 2000 / H 4000

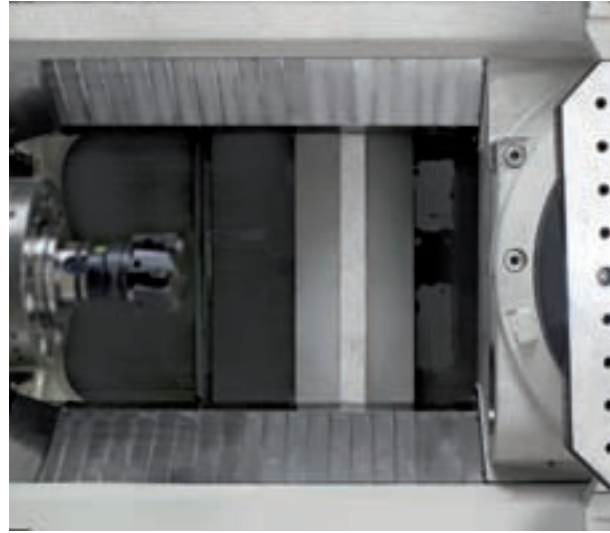

Work area

Free chip fall, higher accuracy

- Free chip fall below the spindle and between rotary table and pallet changer, steep chip chutes in work area and setting station
- Scraping conveyor 600mm wide covering the complete Z-stroke
- Minimal chip accumulating surfaces, e. g. rotary table has integrated motor
- Cooling channels inside the tool are purged after use of internal coolant, functional surfaces at the rotary table and setting station are air-blasted
- No swarf dispersion from the machine bed since Z-axis cover does not exit the work area
- Bright work area lighting

The benefits to you:

- Reduced downtimes due to contamination, extended cleaning intervals
- Reduced production costs
- Higher workpiece precision

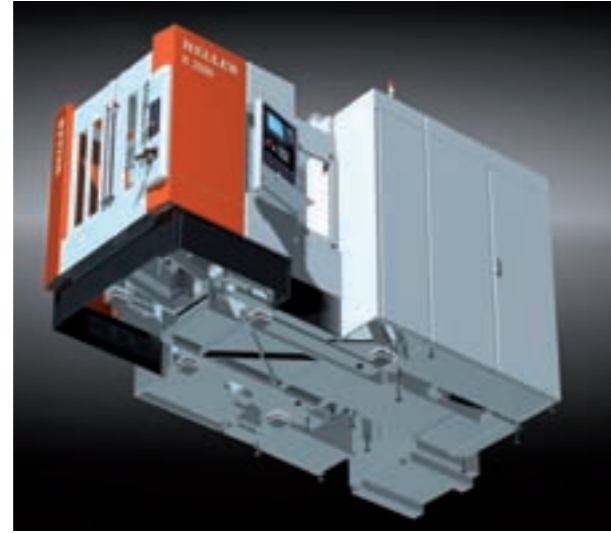

Space requirements

Smaller footprint, reduced costs, faster installation

- Components and units fully integrated into the machine structure
- Very compact control cabinet, identical for all machine types
- Compact design provides very small footprint in this machine range
- Installation without anchoring on vibration-damping levelling shoes
- Low overall weight

The benefits to you:

- Reduced space and foundation requirements save infrastructure costs
- Machine easier to relocate due to quick and easy installation
- Good vibration insulation provides enhanced machining accuracy



Workpiece management

More space, less chip deposits

- Rigid rotary table with two separate Z-axis guideways
- New brake system provides high clamping force in the B-axis of the rotary table
- High workpiece mass of up to 1,000 kg or 1,400 kg
- Hydraulic workpiece clamping available as an option
- Air blast for functional surfaces (rotary table and setting station)
- Pallet changer with reduced chip accumulating surfaces
- Friction-locked 4 x 90° indexing at the setting station with foot release

The benefits to you:

- Allows machining of large workpiece geometries and masses
- High process stability thanks to new rotary table clamping
- Compact rotary table provides optimised chip flow
- High machining accuracy through reduced chip deposits and pneumatic cleaning
- Good accessibility to stationary hydraulic valves on the switchboard



Tool management

Customised to your requirements

- Chain-type tool magazine with 54 places as standard, optional chain-type magazine with 80 or 160 places or rack-type magazine with more than 400 places
- Tool lengths up to 450 mm, tool diameters up to 160 mm
- 2-axis servo-changer provides shortest chip-to-chip times
- Fast tool break monitoring with reference measurement (option)
- Tactile tool measuring system (option)
- Tool coding (option)
- SK 40, HSK 63, BT 40 spindle tapers

The benefits to you:

- Wide range of tools and tool geometries
- Re-use of existing cutting tools
- New operating strategy for short tool loading times
- Tool condition monitoring minimises downtimes

The right tool for each operation

Spindle

Different spindle versions for high productivity

Workpiece management

Quick and easy handling of large workpieces

Tool management

Customised to your requirements

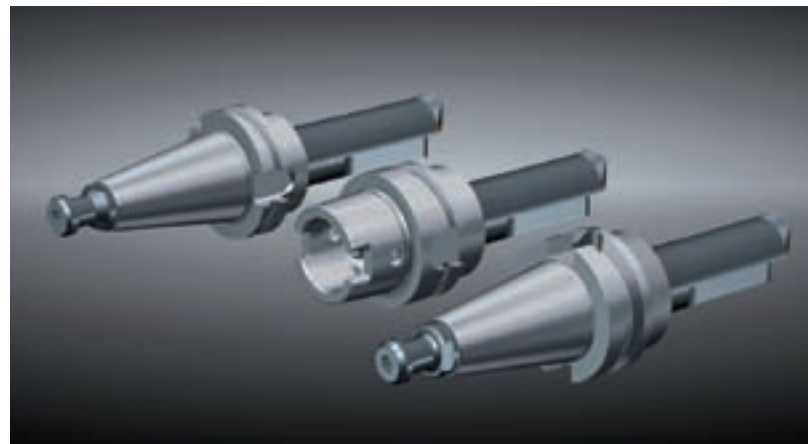

- SK 40 spindle taper acc. to DIN 69871 form A, AD or B with pull stud acc. to DIN 69872 form A or B
- HSK 63 spindle taper acc. to DIN 69893 form A
- BT 40 spindle taper acc. to JIS B 6339-1992 with pull stud JIS B 6339-1992 40P

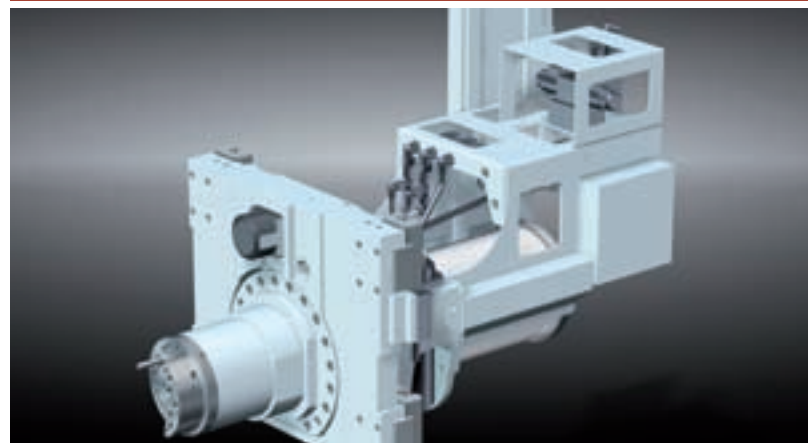

- EcoCutting: 10,000 1/min / 17 kW / 81 Nm
- PowerCutting: 10,000 1/min / 38 kW / 242 Nm
- SpeedCutting: 16,000 1/min / 40 kW / 96 Nm
- HighSpeedCutting: 24,000 1/min / 25 kW / 40 Nm

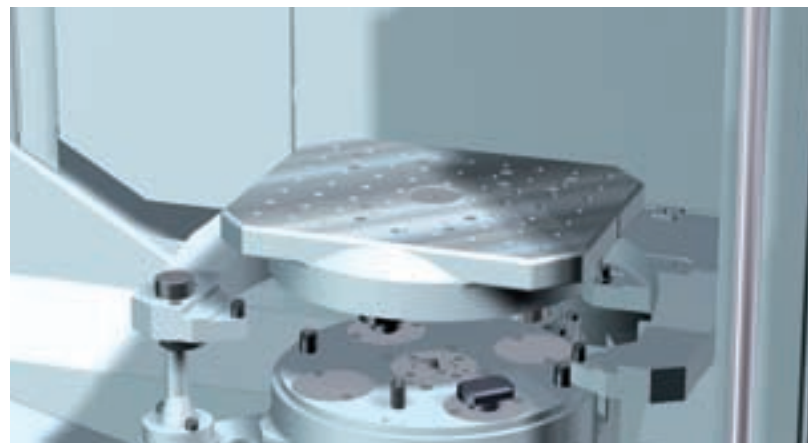

- High clamping force in the B-axis
- High workpiece mass of up to 1,000 kg or 1,400 kg
- Friction-locked 4 x 90° indexing at the setting station with foot release
- Automatic rotating setting station and automatic setting station door (option)
- 60 bar or 200 bar hydraulic workpiece clamping (option)
- 200 bar workpiece clamping with proportional control (option)



- Chain-type tool magazine with 54, 80 or 160 places
- Rack-type magazine with more than 400 places
- 2-axis servo-changer provides shortest chip-to-chip times
- Optional cleaning of tool cartridges and holders
- Tool loading to rack-type magazine parallel to machining (option)
- Fast tool break monitoring with reference measurement (option)
- Tactile tool measuring system (option)

Extensions and options

Typical extra quality from HELLER



- SINUMERIK 840D solution line or Fanuc 310i-A
- Operating modes 2 and 3 included in standard scope of supply
- Increased operator convenience
- Pallet and job management
- Automatic return to home position
- Graphical diagnostic tools
- Remote diagnostics of the machine and coolant unit
- Comprehensive option package



- Standardised interface to linkage systems (option)
- Rotary pallet pool with 6 pallets in the system (option)



- Scraping conveyor
- Mesh-type filter with 12 bar pump: optional work area shower
- Paperband filter with 12 bar pump: work area shower, 50 bar or 70 bar high pressure pump, option
- Vacuum rotation filter with 50 bar high pressure pump: work area shower, 70 bar high pressure pump, option

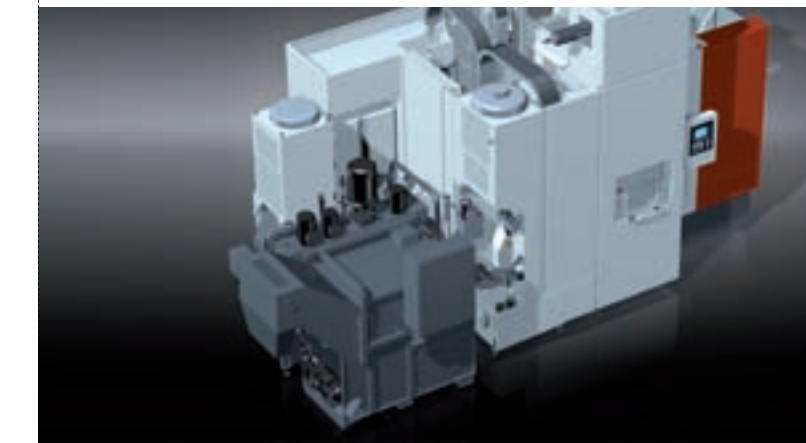

- Multi-spindle head location
- Measuring probe
- Minimal quantity lubrication with single-channel MQL unit



State-of-the-art high-end control technology

SPEED PACK: for high-speed cutting



For flexible integration into manufacturing systems

The perfect solution for all strategies

Ready for the requirements of day-to-day production



Enough is better than too much.

Based on our experience we are offering two different packages for the H series tailored to the specific requirements of our customers. Your package benefit: you get exactly the performance you need at a cost-effective price.

For high-speed cutting

The SPEED PACK has been specifically designed for high-speed machining of light metals. Two different spindles with HSK 63 spindle taper are available: the standard spindle with 16,000 1/min, a spindle power of 40 kW and a torque of 96 Nm. Optionally, a spindle with 24,000 1/min is available.

The SPEED PACK also provides high axis dynamics: the H series provides a maximum acceleration of 10 m/s² and a maximum rapid traverse of 90 m/min. A newly developed 2-axis servo-changer ensures shortest tool change times and ultra-short chip-to-chip times. A real added benefit of the H series is its robust design. Quick and efficient coolant disposal is guaranteed via a paperband filter unit.

SPEED PACK includes

- SpeedCutting unit with 16,000 1/min
- 10 m/s² acceleration and 90 m/min rapid traverse
- Paperband filter unit and work area flushing
- HSK 63 spindle taper
- Chain-type magazine with 54 places
- NC rotary feed table

Extensions

- HighSpeedCutting unit with 24,000 1/min
- 60 or 200 bar hydraulic workpiece clamping
- Chain-type tool magazine with 80 or 160 places or rack-type magazine with 400 places including wet tool cleaning
- Measuring probe and numerous software options

POWER PACK: for heavy cutting

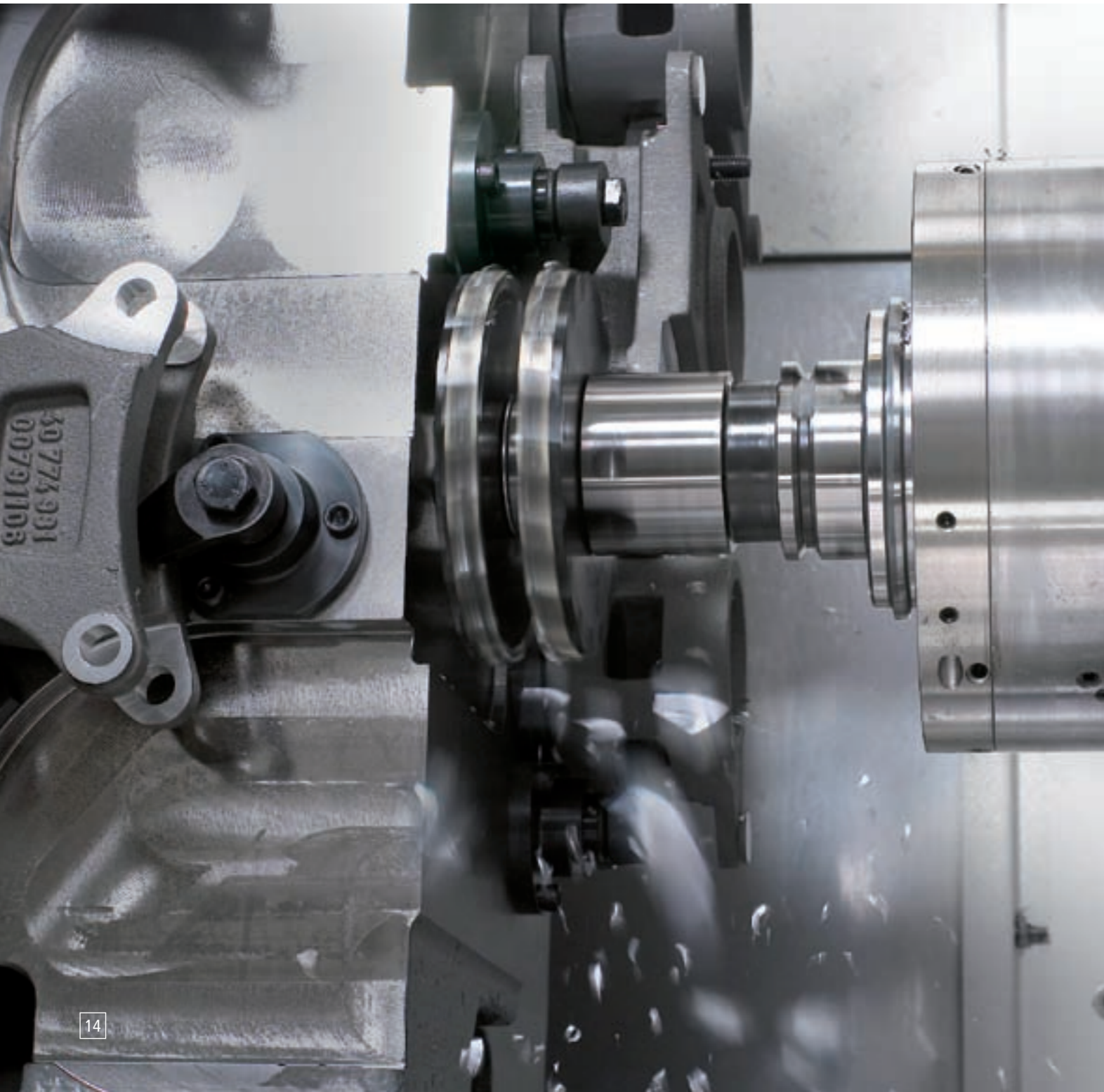
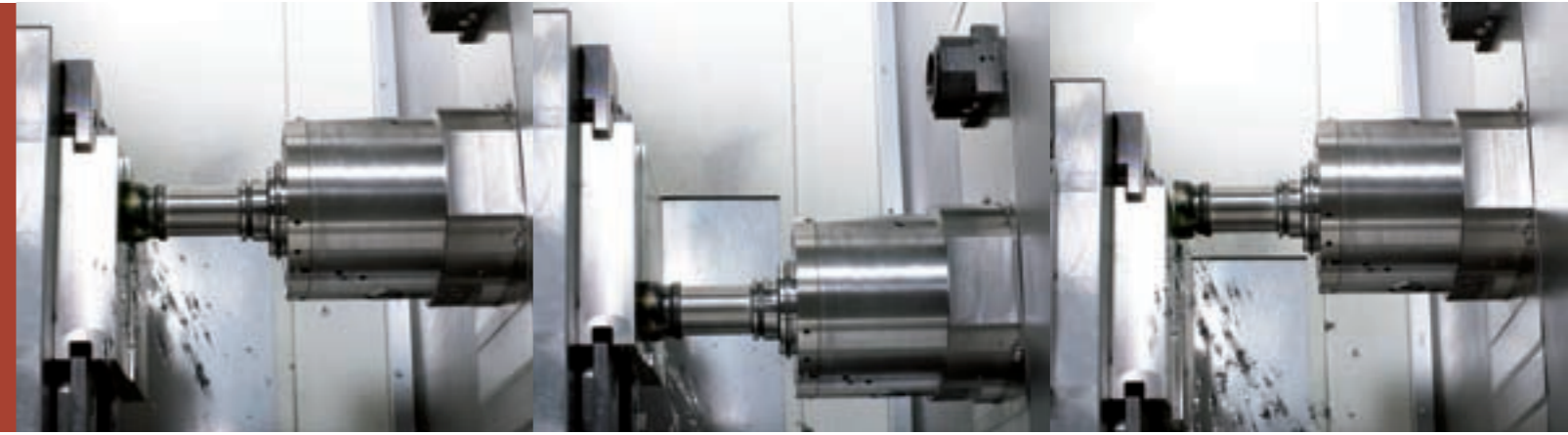

Power at your fingertips

Two things are essential for series machining of cast iron and steel materials: the performance and load capacity of a machining centre. The POWER PACK fulfils exactly these requirements.

For heavy cutting

The drive concept and spindle included in the POWER PACK are specifically geared to performance. The spindle provides a torque of 242 Nm, a spindle power of 38 kW and a speed of 10,000 1/min – ideal for series production of cast iron and steel parts. The POWER PACK comes with work area flushing and a paperband filter unit with a 50 bar high-pressure pump. Depending on your daily requirements you can select an SK, HSK or BT spindle taper. With its sturdy basic design and high load capacity the POWER PACK sets new standards.

POWER PACK includes

- PowerCutting unit with 10,000 1/min, 242 Nm torque and 38 kW power
- Paperband filter unit and work area flushing
- SK 40, HSK 63 or BT 40 spindle taper
- Chain-type magazine with 54 places
- NC rotary feed table

Extensions

- 60 or 200 bar hydraulic workpiece clamping
- Chain-type tool magazine with 80 or 160 places or rack-type magazine with 400 places including wet tool cleaning
- Measuring probe and numerous software options

Operation: proven and perfected

Scores well for everyday use

The productivity of a machine tool is defined by its cutting performance and reliability, while safety and ease of operation play a major role for its availability. With the H series you can profit from our application experience day in and day out.

The operating stations of the machine are arranged for optimum accessibility; the reach to the setting station centre is conveniently short to make workpiece handling easy. The tool loading station provides a very practical function: tools can be loaded while the spindle is running, so no time is wasted.



■ Helpful in day-to-day production: linear guideways provide smooth operation of the setting station doors.



■ Practical feature: the ergonomic operating panel is integrated into the safety guards.

Programming in the familiar system environment

Concentrated application know-how also forms the basis for the state-of-the-art high-end control technology incorporated in the H series.

The benefit to you: programming takes place in the well-known system environment with either SINUMERIK 840D solution line or Fanuc 310i-A. Both controls feature a nearly identical range of options. The basic configuration comprises the integrated safety functions, operating modes 2 and 3 and tool loading during machining to save time.



■ Convenient: optional operating panel with display at the tool loading station.

Maintenance: done in a flash



Optimised life cycle costs

The acquisition costs are only one factor affecting the overall costs of a machine - another important aspect to consider are the maintenance costs. The H series features a number of innovations that provide a real benefit in terms of life cycle costs.

All function-relevant systems and components incorporated in the H series are installed within quick and easy reach. For example: components arranged for ease of maintenance and removable guard panels provide access at the touch of a hand. What is more,

the Z-axis cover and the spindle can be replaced in no time at all thanks to the proven zero-spindle system. In most cases, maintenance and servicing or even repairs can be performed in a few easy steps. The quick response times of the HELLER spare parts service also help to keep production downtimes short. Service and maintenance points are limited to a few locations to allow for easy inspection and operation.

We are here for you. Worldwide.

HELLER locations



GERMANY

Gebr. Heller Maschinenfabrik GmbH
Gebrüder-Heller-Strasse 15
72622 Nürtingen
Telephone +49 7022 77-0
Telefax +49 7022 77-5000
sales@hnt.heller-machines.com

HELLER Services GmbH
Nürtingen
Gebrüder-Heller-Strasse 15
72622 Nürtingen
Telephone +49 7022 77-0
Telefax +49 7022 77-1200
services@hnt.heller-machines.com

HELLER Services GmbH
Chemnitz
Sandstrasse 116
09114 Chemnitz
Telephone +49 371 844949-0
Telefax +49 371 8449-2720
services@hdo.heller-machines.com

HELLER Services GmbH
Goslar
Vor dem Nordhees 12
38644 Goslar-Jerstedt
Telephone +49 5321 6834-0
Telefax +49 5321 6834-2199
services@hdm.heller-machines.com

HELLER Services GmbH
Hattingen
Hüttenstrasse 45
45527 Hattingen
Telephone +49 2324 9245-0
Telefax +49 2324 9245-2399
services@hdn.heller-machines.com

HELLER Services GmbH
Saarbrücken
Neumühlerweg 75
66130 Saarbrücken-Güdingen
Telephone +49 681 88372-0
Telefax +49 681 88372-2044
services@hdw.heller-machines.com

HELLER Services GmbH
Kirchheim
Paracelsusstrasse 3
73230 Kirchheim
Telephone +49 7021 80758-0
Telefax +49 7021 80758-2699
services@hdu.heller-machines.com

HELLER Services GmbH
Salem
Am Riedweg 16
88682 Salem-Neufrach
Telephone +49 7553 91677-0
Telefax +49 7553 91677-2266
services@hds.heller-machines.com

HELLER Services GmbH
Nürnberg
Vogelweiherstrasse 33
Gebäude M4 – 2. Obergeschoss
90441 Nürnberg
Telephone +49 911 400896-0
Telefax +49 911 400896-2819
services@hdf.heller-machines.com

BRAZIL

HELLER Máquinas Operatrizes
Indústria e Comércio Ltda.
Rua Joaquim Machado, 250
Bairro Aparecidinha
Caixa Postal 126
18087-280 Sorocaba - São Paulo
Telephone +55 15 2103-3223
Telefax +55 15 2103-3032
vendas@hbr.heller-machines.com

CHINA

HELLER Machinery & Trading (Shanghai) Co., Ltd.
Rm. 4402-4403, Shanghai Maxdo Centre
No. 8 Xing Yi Road
HongQiao Development Zone
200336 Shanghai
Telephone +86 21 52080485
Telefax +86 21 52080495
sales@heller-machinetools.com.cn

Gebr. HELLER Maschinenfabrik GmbH
Beijing Representative Office
China Merchants Tower
Rm. 140 E, 14. Floor, No. 118 Jian Guo Road
Chaoyang District
100022 Beijing
Telephone +86 10 65670491
Telefax +86 10 65670492
sales@heller-machinetools.com.cn

FRANCE

HELLER Machines Outils
5, rue Saarinen
Silic 128
94523 Rungis Cedex
Telephone +33 1.46.87.34.52
Telefax +33 1.45.60.54.84
ventes@hfr.heller-machines.com

GREAT BRITAIN

HELLER Machine Tools Ltd.
Acanthus Road
Ravensbank Business Park
Redditch, Worcs. B98 9EX
Telephone +44 121 275-3300
Telefax +44 121 275-3380
sales@huk.heller-machines.com

ITALY

HELLER Italia Macchine Utensili S.r.l.
Via Leonardo Da Vinci, 5
37029 San Pietro in Cariano
Verona
Telephone +39 45 6838-231
Telefax +39 45 6838-234
vendite@hit.heller-machines.com

MEXICO

HELLER Machine Tools de Mexico
S. de R.L. de C.V.
Cortazar No. 102 – Col. Hidalgo
C.P. 37329 Leon, Gto.
Telefon +1 248 288-5000
Telefax +1 248 288-9560
sales@hus.heller-machines.com

SLOVAKIA

HELLER Services s.r.o.
Hlavaná 1409 / 48
95201 Vrable
Telephone +421 37776-8300
Telefax +421 37776-8309
services@hsk.heller-machines.com

SPAIN

HELLER Iberica Machine Tools, S.L.
Antic Cami de Caldes, 1 b
08480 L'Ametlla del Vallès
Barcelona
Telephone +34 93 8430209
Telefax +34 93 8430333
ventas-iberica@heller.de

USA

HELLER Machine Tools L.P.
1225 Equity Drive
Troy, Michigan 48084
Telephone +1 248 288-5000
Telefax +1 248 288-9560
sales@hus.heller-machines.com